

- 1. cont** (e) The shop decides that a new product is to be included. *A4 blank red card* must be added to the data after the white card.

State the changes that would have to be made to include this new product in the correct place.

- (f) The shop also used the package to display its Monthly Sales as shown below.

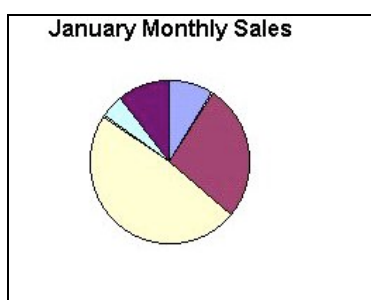

Name the feature of the package which has been used.

KU	PS
	2 1 0
	1 0

2. A video production company has 230 employees. It uses a computer to store the following information about each employee. Part of the file is shown below:

Payroll no	: 0156
Forename	: John
Surname	: Paterson
Address	: 12 Hillcroft Crescent
Hours worked	: 38
Rate of pay	: £8.50
Total pay	: £323.00

- (a) (i) What application package has the video company used to store the employees details?

- (ii) How many fields are there in the example above?

- (iii) How many records are there in the example above?

- (b) (i) The video production company has appointed a new manager. Which of the following would need to be added to the employees details?
Tick (✓) **one** box only.

Field Record File

- (ii) The video production company has decided to store each employee's postcode. Which of the following would need to be added to the employees details?
Tick (✓) **one** box only.

Field Record File

- (c) The video production company uses the computer to search and sort the employees details. Complete the following sentences using the words *search* or *sort*, followed by the *name of the field* used in each case.

- (i) To obtain a list of all employees who worked over 35 hours, the company would

_____ on the _____ field.

- (ii) To obtain a list of all employees in order of Payroll no, the company would

_____ on the _____ field.

KU	PS
	1 0
	1 0
	1 0
	1 0
	2 1 0
	2 1 0

2. (c) (iii) To obtain a list of all employees in alphabetical order of Surname, the company
cont

would _____ on the _____ field.

(d) What data types would be used for the fields:

(i) Forename: _____

(ii) Hours worked: _____

KU	PS
	2 1 0
	2 1 0

3. (a) Choose the correct word from the list below to complete the following sentences.

bytes kilobytes terabytes gigabytes

- (i) A terabyte is 1024 _____
 A kilobyte is 1024 _____
 A gigabyte is 1024 _____

(ii) How many bits make up a byte? _____

(b) (i) Two types of main memory are *ROM* and *RAM*.
 Tick (✓) the correct boxes below to show whether the sentences are true for
 ROM or RAM. The first one is done for you.

	ROM	RAM
Data is lost when the power is switched off	<input type="checkbox"/>	<input checked="" type="checkbox"/>
Data cannot be altered	<input type="checkbox"/>	<input type="checkbox"/>
Data is stored permanently	<input type="checkbox"/>	<input type="checkbox"/>
Stores data and programs while the program is in use	<input type="checkbox"/>	<input type="checkbox"/>

(ii) If a computer has main memory why do we need backing storage devices?

(c) Write the following hardware under the correct heading.

Trackball DVD-Rom drive Laser printer
Plotter Magnetic tape unit Joystick

Input Device	Output Device	Backing Storage Device

KU	PS
3	
2	
1	
0	
1	
0	
3	
2	
1	
0	
6	
5	
4	
3	
2	
1	
0	

3. (d) Choose the correct word from the list below to complete the following sentence.
cont

File *Program* *Directory*

The operating system is a _____ which controls the operation of a computer system.

(e) Using the words below, complete the diagram that represents a simple computer system.

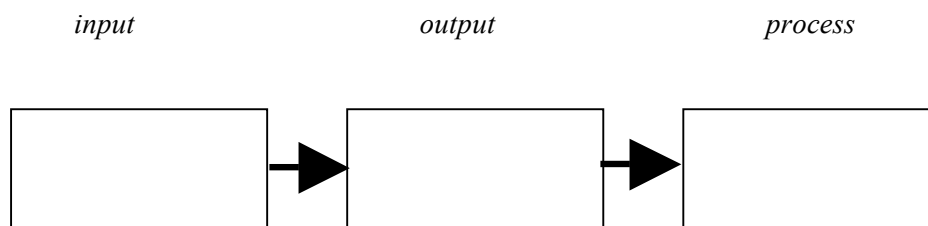

KU	PS
1 0	
3 2 1 0	

4. A letter is going to be sent out to the parents of children going on a school trip to Paris. A draft copy with suggested changes is shown below.

Paris trip ~~2005~~ ²⁰⁰⁶

Dear Parents

The second payment is now ~~due due~~. Cash or cheques made payable to the school should be handed in to Mr. Clark by ~~by~~ ^{this} Thursday.

Ronald Clark
Trip Organiser

- (a)
- (i) Which piece of text has to be *deleted*? _____
- (ii) Which piece of text has to be *inserted*? _____
- (iii) Which piece of text has to be *amended*? _____

- (b) The second draft is shown below with the above changes.

Paris trip 2006

Dear Parents

The second payment is now due. Cash or cheques made payable to the school should be handed in to Mr. Clark by this Thursday.

Ronald Clark
Trip Organiser



State **three** other changes which have been made to the letter.

1. _____
2. _____
3. _____

KU	PS
	3
	2
	1
	0
	3
	2
	1
	0

5. Mabel is a Chemistry student and she is producing her final lab report.

- (a) (i) The students were all given a *template* to use for the lab report.
Explain what is meant by a template.

- (ii) Give **one** advantage to the students of using a template.

- (b) Mabel inserted a graphic in her lab report. She used a *wizard* to help her do this.
Explain what is meant by a wizard.

- (c) The graphic Mabel inserted is shown below.

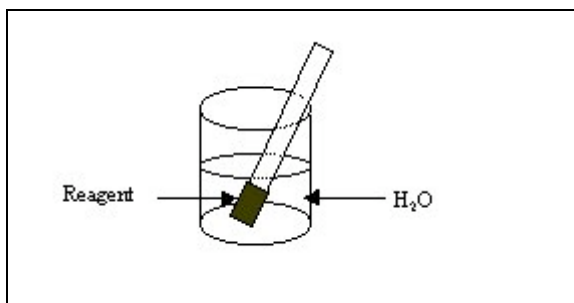

Name or describe **three** graphic tools that have been used to create this graphic.

1. _____
2. _____
3. _____

KU	PS
2	1
1	0
0	1
	0
1	0
0	0
	3
	2
	1
	0

5.
cont

(d) Mabel decides to E-mail her lab report to her Professor rather than sending it by post.

(i) What additional piece of hardware is needed to allow Mabel to do this?

(ii) Give **one** advantage to Mabel of using E-mail rather than sending it by post.

(e) Mabel uses a WAN to send her lab report. The university has a LAN.

(i) What does WAN stand for?

W _____ A _____ N _____

(ii) What does LAN stand for?

L _____ A _____ N _____

(iii) Give **two** advantages for the university of using a LAN instead of several stand-alone computers.

1. _____
2. _____

(iv) Mabel sends her report using *e-mail*.

What does the “e” stand for in “e-mail”?

KU	PS
1 0	
	1 0
1 0	
1 0	
	2 1 0
1 0	

6. Sam has booked her holiday through a travel agents.

(a) Travel agents use a *terminal* linked to a *mainframe computer system*. The mainframe stores and processes all the holiday information.

(i) What is meant by a terminal?

(ii) Give **two** reasons why a mainframe computer system would be used to store and process all the holiday information?

Reason 1.

Reason 2.

(b) Backup copies of the data are taken regularly.

(i) Why is a backup copy needed?

(ii) Suggest a suitable backing storage medium that could be used to store the holiday information.

(c) Sam decides to buy some new clothes for her holiday. She uses *on-line shopping*.

(i) What is meant by on-line shopping?

KU	PS
1 0	
	1 0
	1 0
1 0	
	1 0
1 0	

